

EXPLODED VIEW - V2.2

PAGE 1

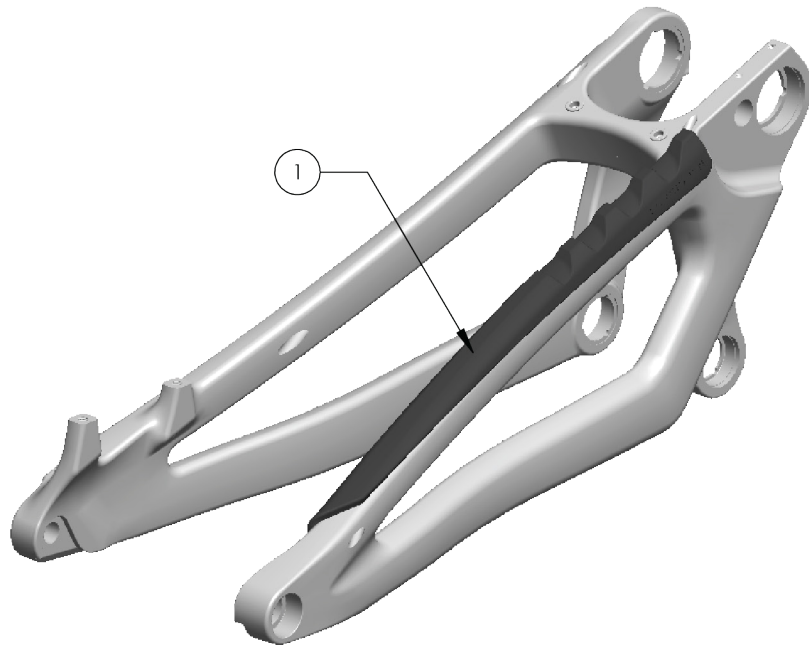

ITEM NO.	DESCRIPTION	QTY
1	004.002.0003 - CHAINSTAY PROTECTOR	1



ATTENTION: ENSURE SURFACE IS CLEAN AND FREE FROM GREASE!



ATTENTION: ENSURE CORRECT ALIGNMENT!

EXPLODED VIEW - V2.2

PAGE 2



ITEM NO.	DESCRIPTION	QTY
2	ENDURO 6902 LLU MAX	2
3	ENDURO 6904 LLU MAX	2

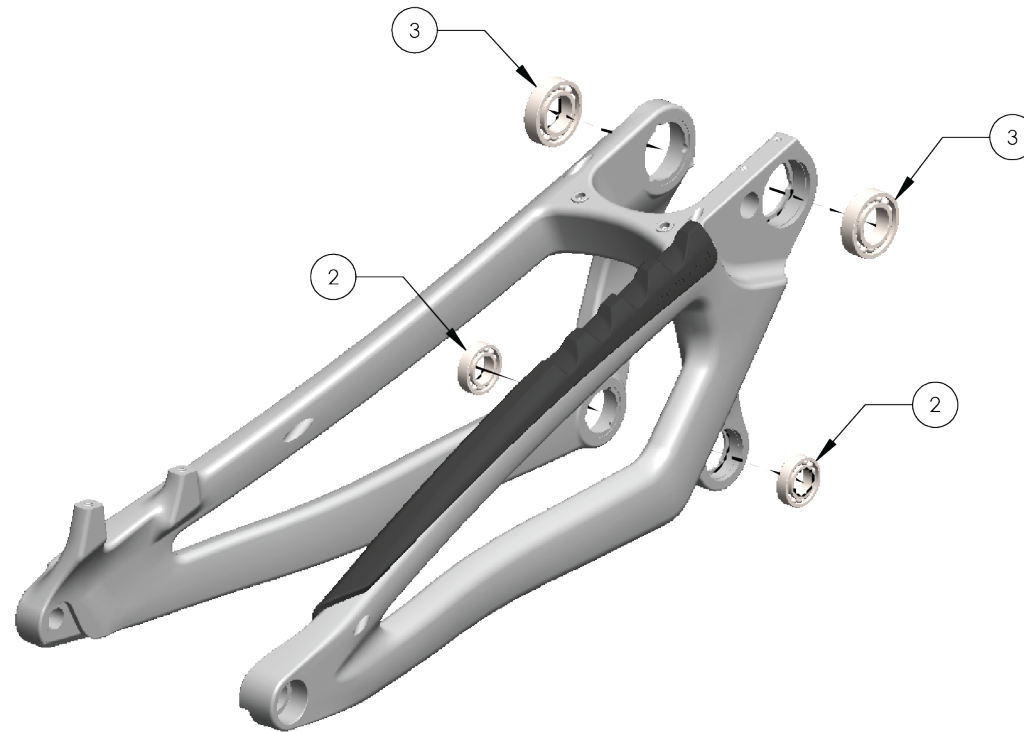

ATTENTION: APPLY LIGHT FILM OF GREASE TO BEARING BORES BEFORE INSTALLATION!

EXPLODED VIEW - V2.2

PAGE 3



ITEM NO.	DESCRIPTION	QTY
2	ENDURO 6902 LLU MAX	2

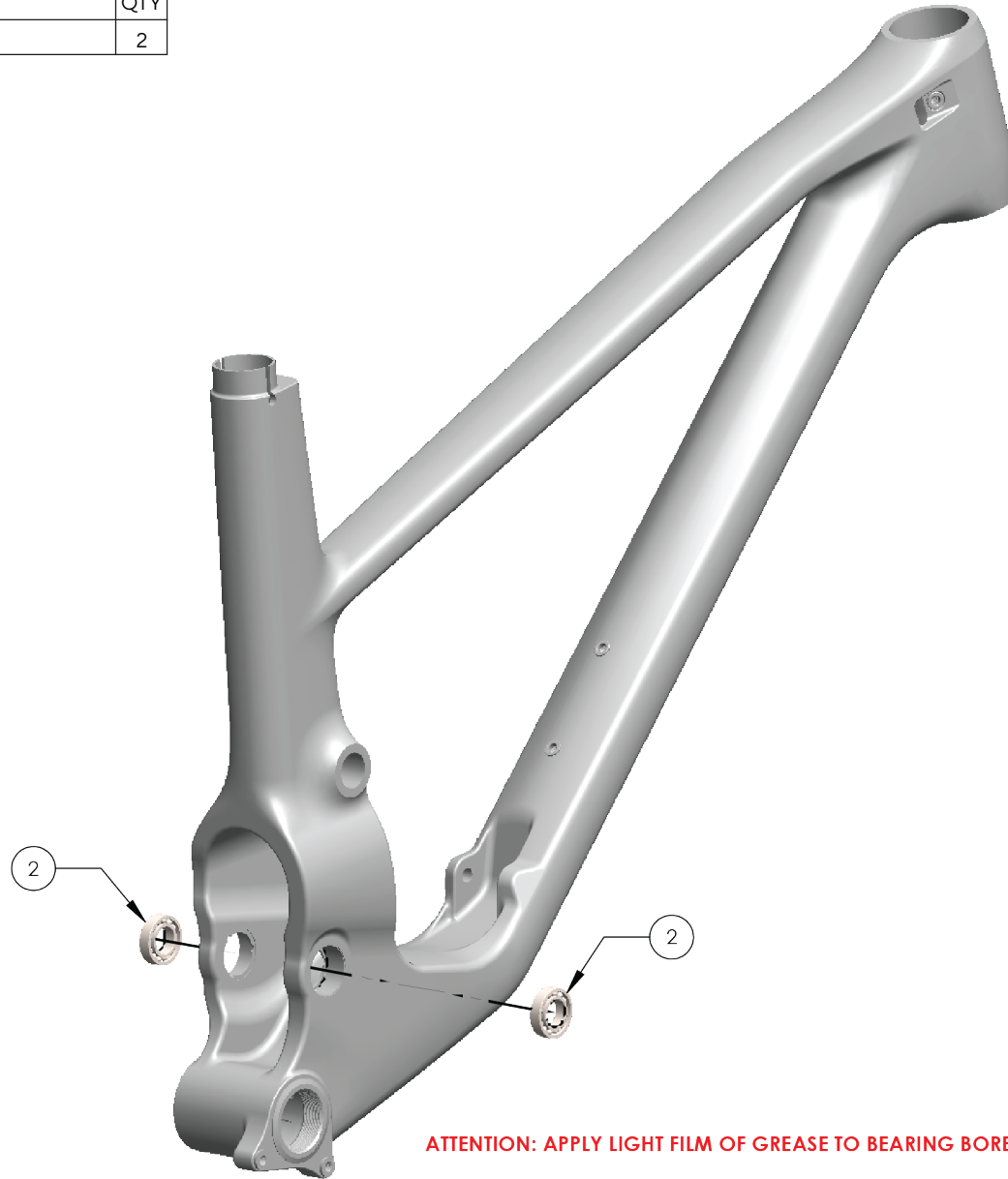

ATTENTION: APPLY LIGHT FILM OF GREASE TO BEARING BORES BEFORE INSTALLATION!



EXPLODED VIEW - V2.2

PAGE 4



ITEM NO.	DESCRIPTION	QTY
4	001.001.0004 (ALT - 001.001.0006) - ROCKER LINK	1
5	002.004.0007 - SPACER 15x4	1
6	ENDURO 3802 LLU MAX	2

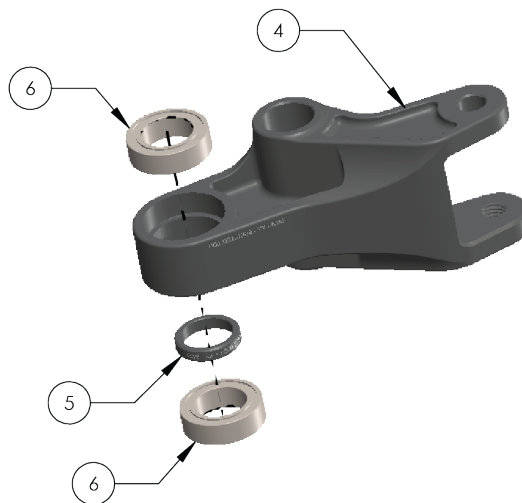

ATTENTION: APPLY LIGHT FILM OF GREASE TO BEARING BORES BEFORE INSTALLATION!

ITEM NO.	DESCRIPTION	QTY
7	ENDURO 6902 LLB ABEC 5	1
8	INTERNAL RETAINING RING 28mm BORE	1
9	003.001.0005 - IDLER PULLEY 16T	1

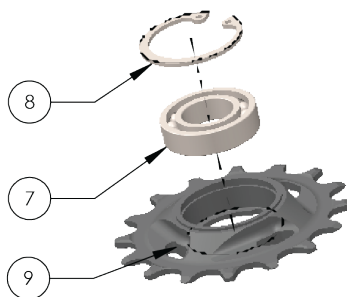

ATTENTION: APPLY LIGHT FILM OF GREASE TO BEARING BORES BEFORE INSTALLATION!



EXPLODED VIEW - V2.2

PAGE 5



ITEM NO.	DESCRIPTION	QTY
10	E13 UPPER GUIDE	1
11	004.002.0002 - REAR TRIANGLE FENDER	1
12	003.005.0003 - REAR AXLE	1
13	003.002.0001 - DERAILLEUR HANGER	1
14	003.002.0002 - DERAILLEUR HANGER	1
15	003.001.0003 - IDLER PULLEY SHAFT	1
16	003.007.0003 - CHAINGUIDE SCREW	2
17	003.007.0002 - ACCESSORY SCREW	2

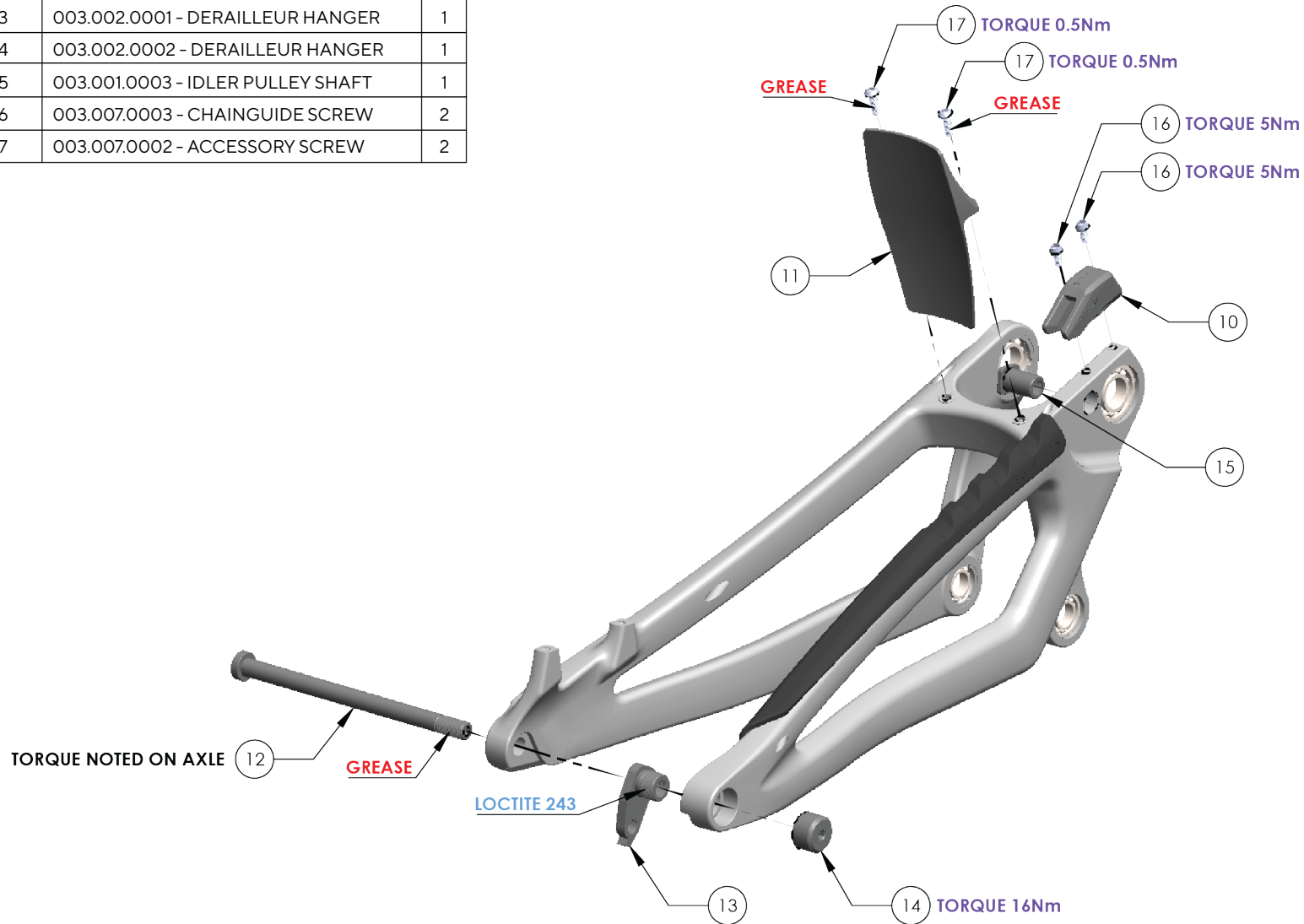

EXPLODED VIEW - V2.2

PAGE 6



ITEM NO.	DESCRIPTION	QTY
18	003.006.0001 - SEAT CLAMP	1
19	003.007.0008 - SEAT CLAMP BARREL	1
20	003.007.0005 - SEAT CLAMP SCREW	1

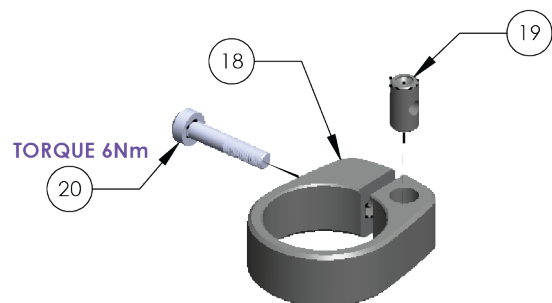

ITEM NO.	DESCRIPTION	QTY
21	004.001.0003 - CABLE PORT SINGLE	1
22	004.001.0002 - CABLE PORT DOUBLE	1
23	004.001.0001 - CABLE PORT DOUBLE ANGLED	1
24	004.002.0001 - DRUID DOWNTUBE COVER	1
17	003.007.0002 - ACCESSORY SCREW	9

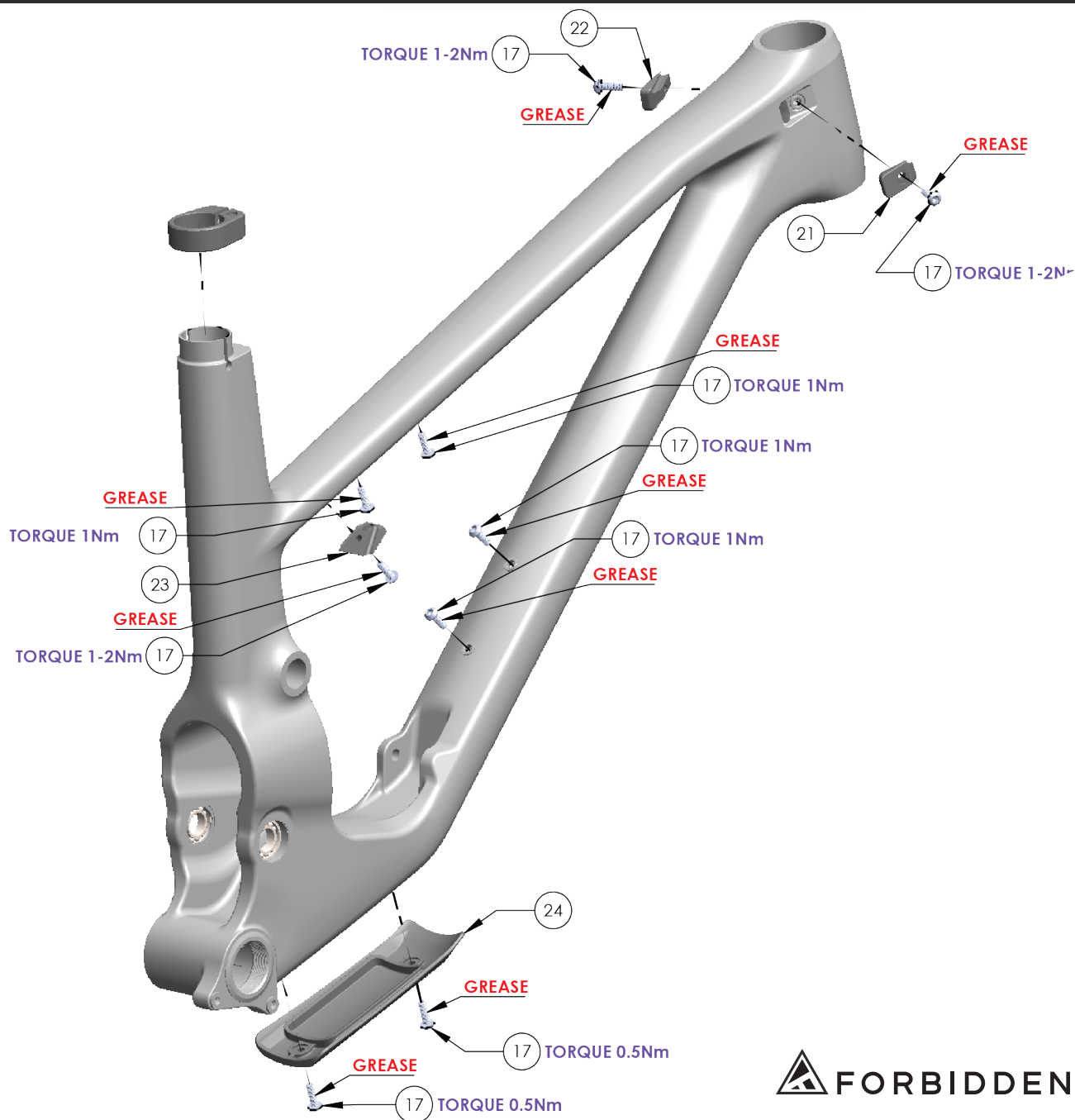

EXPLODED VIEW - V2.2

PAGE 7



ITEM NO.	DESCRIPTION	QTY
25	002.004.0005 - SPACER 15x1.5 FLANGED	2

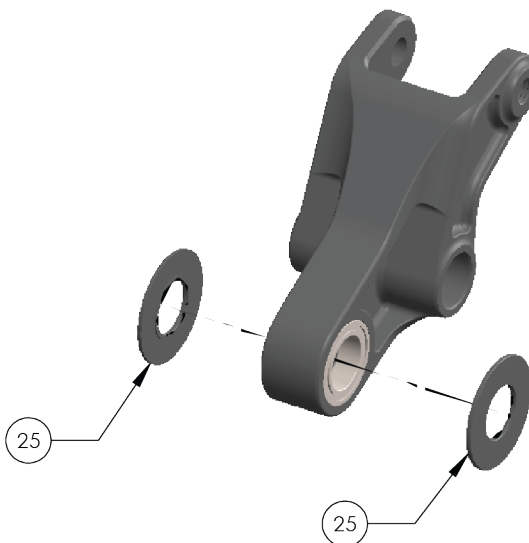

ATTENTION:
ENSURE CORRECT ORIENTATION OF SPACERS.
PART NUMBER FACES BEARING.

ITEM NO.	DESCRIPTION	QTY
26	001.001.0005 - *see note 7A. - PULL LINK	1
27	002.001.0007 - SHAFT 15x30	1

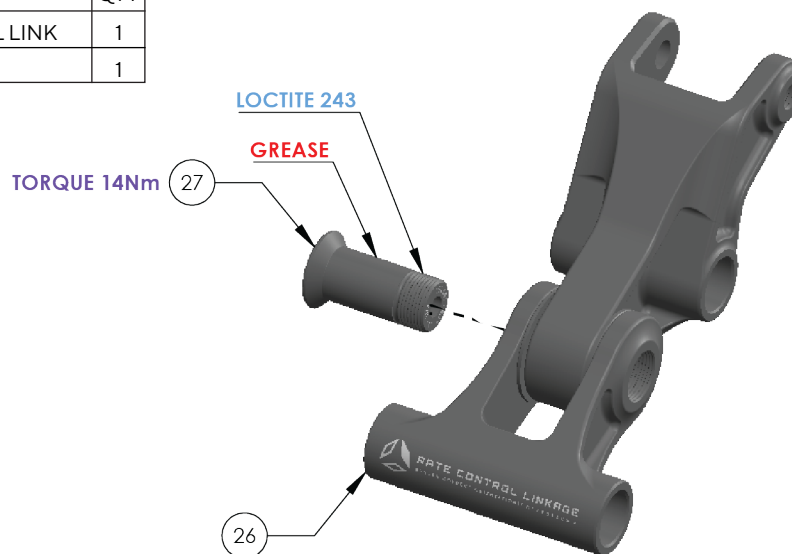

NOTE 7A:
FOR ALL "ZIGGY" ASSEMBLIES
REPLACE 001.001.0005
WITH 001.001.0007



EXPLODED VIEW - V2.2

PAGE 8



ITEM NO.	DESCRIPTION	QTY
28	002.004.0006 - SPACER 15x4 FLANGED 28OD	2
29	002.002.0003 - SCREW 10x13 28OD	1
30	002.001.0005 - SHAFT 15x68 INT 28OD HEAD	1

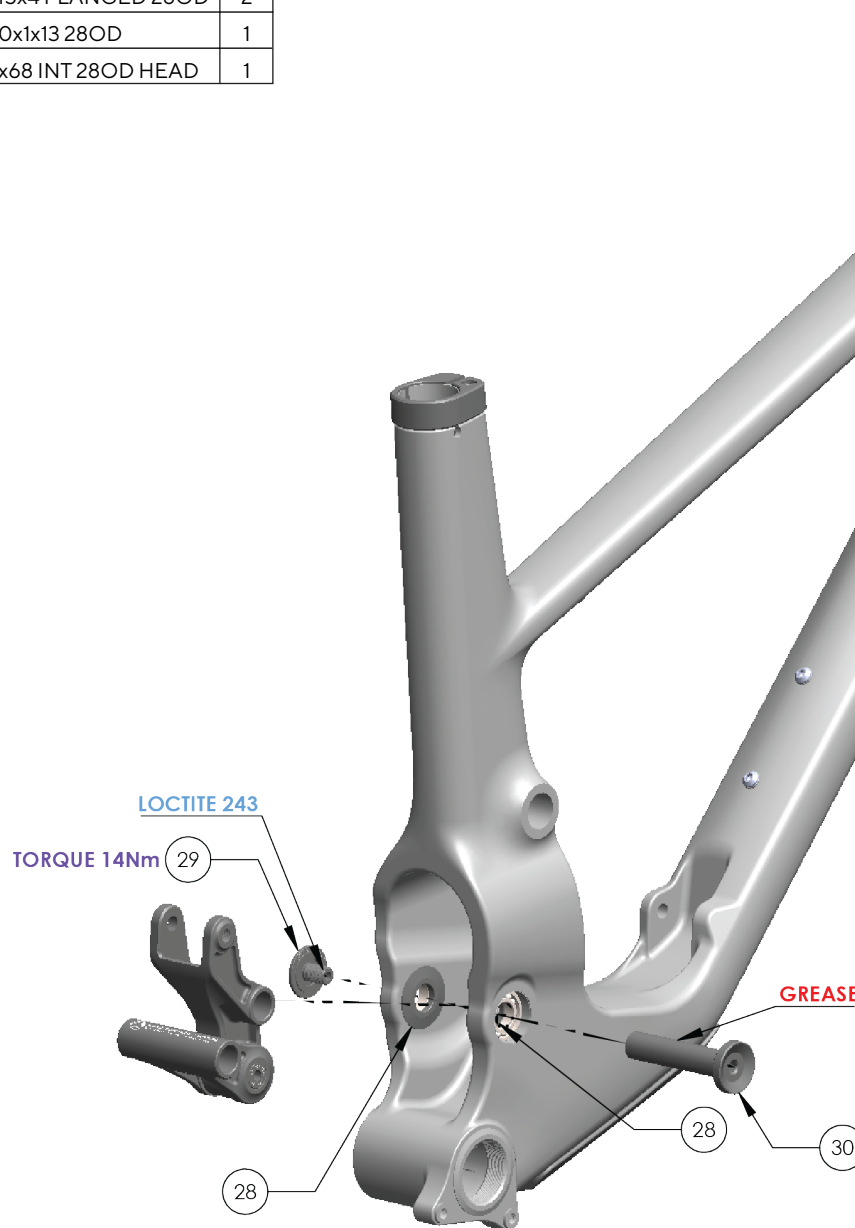

EXPLODED VIEW - V2.2

PAGE 9



ITEM NO.	DESCRIPTION	QTY
28	002.004.0006 - SPACER 15x4 FLANGED 28OD 2	2
29	002.002.0003 - SCREW 10x13 28OD	1
31	002.001.0006 - SHAFT 15x93 INT 28OD HEAD	1
32	002.004.0001 - SPACER 20x4.5	2
33	002.003.0001 - NUT 20x1x8	1
34	002.001.0001 - SHAFT 20x95 EXT	1
35	003.004.0002 - LOCKING COVER	1
36	003.007.0006 - MAIN PIVOT LOCKING COVER SCREW	1

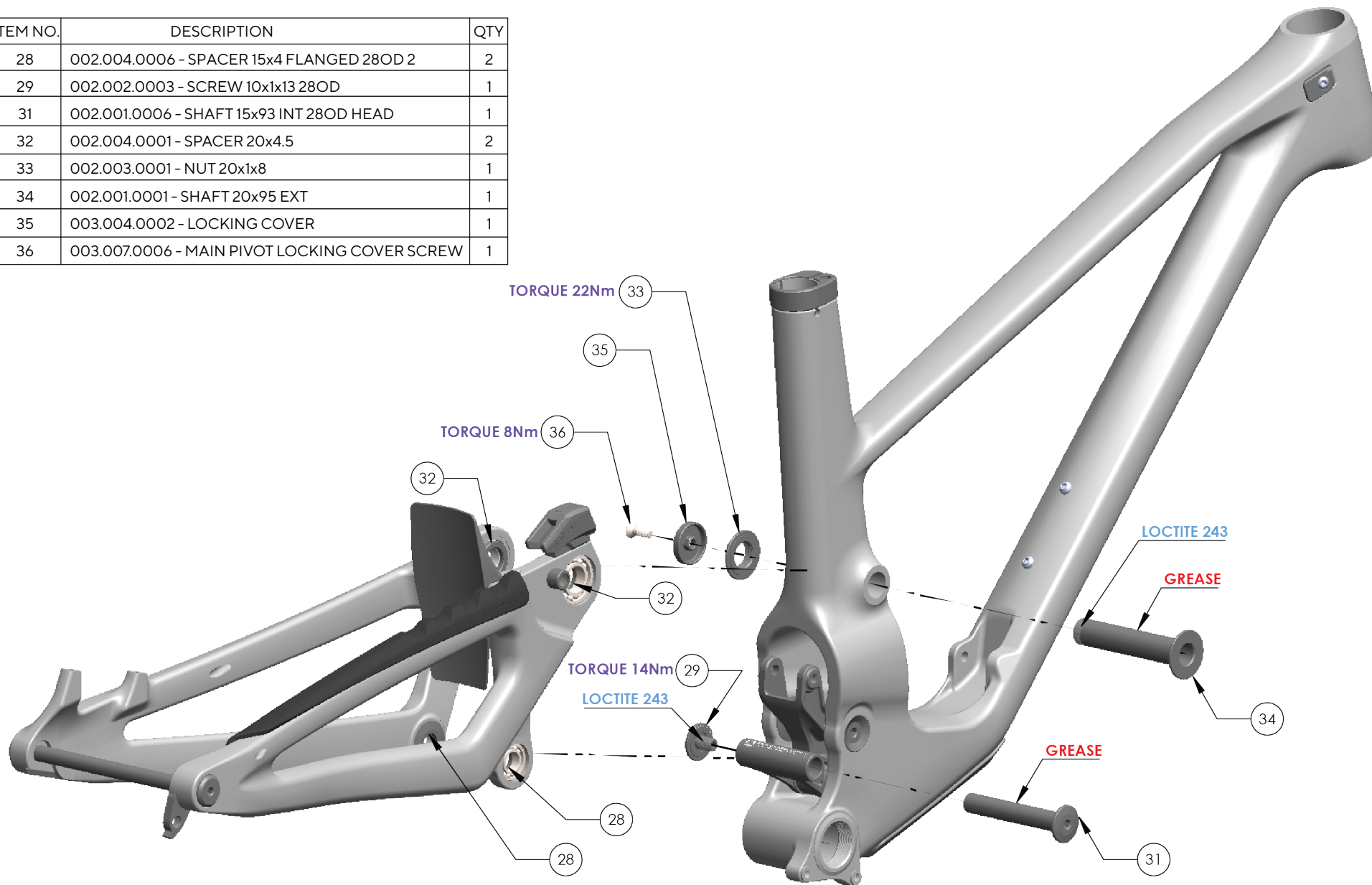

EXPLODED VIEW - V2.2

PAGE 10



ITEM NO.	DESCRIPTION	QTY
37	003.001.0004 - IDLER PULLEY SPACER 15x3	1
38	003.001.0002 - IDLER PULLEY SCREW 10x1	1

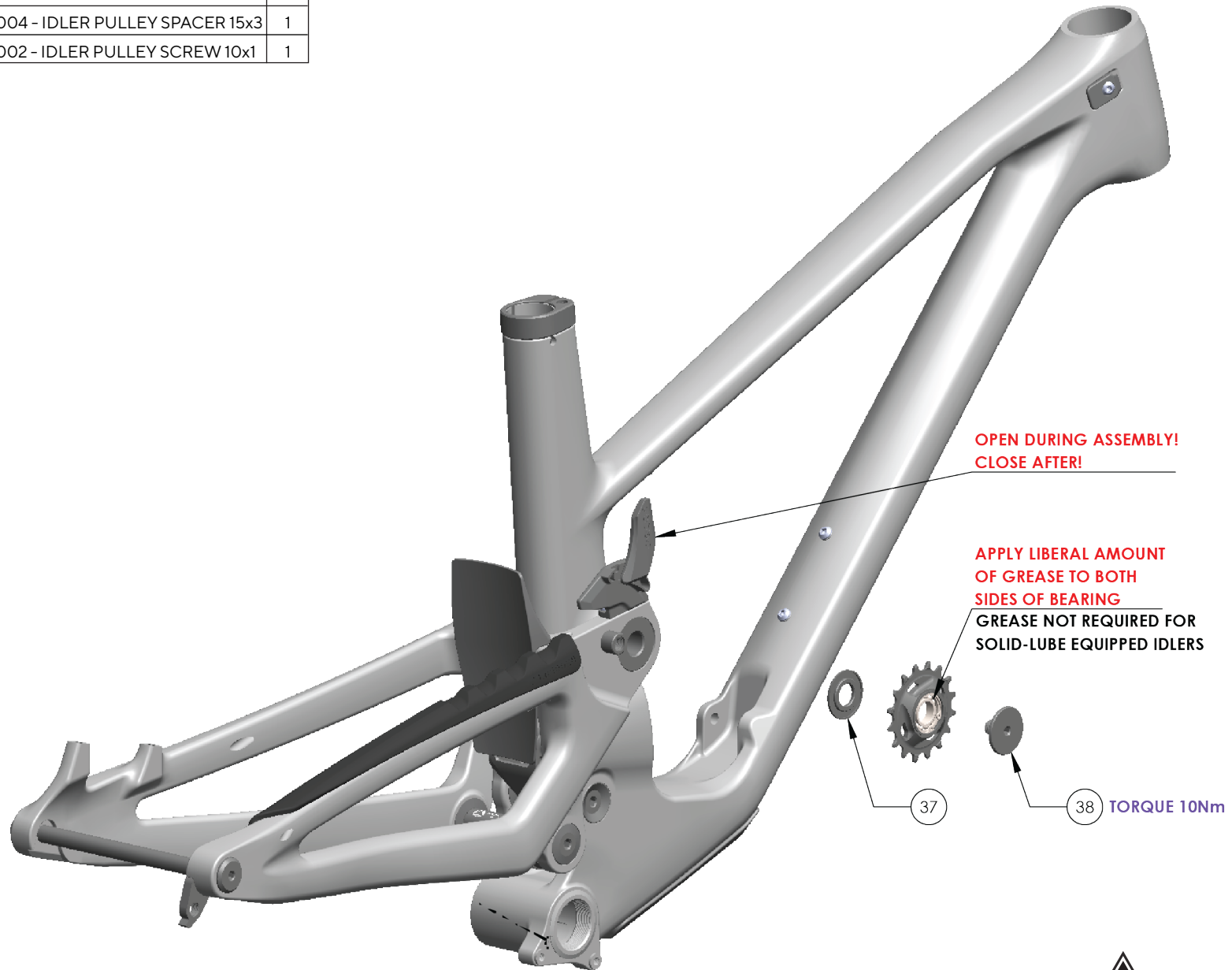

EXPLODED VIEW - V2.2

PAGE 11



ITEM NO.	DESCRIPTION	QTY
41	003.007.0004 - SHOCK SCREW	2

