



DRUID V2 //
52/55mm MODULAR MOUNTING SYSTEM

52/55mm MODULAR MOUNTING SYSTEM // DRUID V2



Your bike is both 52mm and 55mm chainline compatible.

52mm CL - Shimano 11 & 12-speed, SRAM Eagle 12-speed [non T-Type], SRAM 11-speed

55mm CL - SRAM Eagle T-Type

We are able to achieve this by configuring our modular mounting system and idler pulley.

CONFIGURATION MATRIX

IDLER PULLEY MOUNT

IDLER PULLEY ORIENTATION

	Circlip Facing Out	Circlip Facing In
ANGLED 55mm CL Only	55mm Optimized	N/A
52/55mm CL	52mm	*55mm

*If you are using the following configuration seen in the table above.

See pg. 4 for further details.

All complete bike builds with T-Type Drivetrains come with the 'ANGLED 55mm CL Only' Mount. This is our optimized setup that ensures the best chainline for the entire range of the cassette.

Framekits are supplied with both Idler Pulley Mounts allowing you to build the bike the way you want!

Please follow the steps outlined and exploded diagrams to ensure your mounting system is installed and configured correctly.

52/55mm MODULAR MOUNTING SYSTEM // DRUID V2

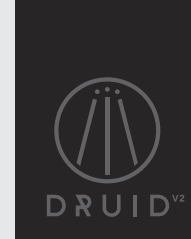

TOOLS NEEDED

You will need a 5mm allen key and a torque wrench (with 5mm allen key head).

STEP 1

Determine which Idler Pulley (IP) Mount you need to fit to your bike.
See table on pg. 1 for details.

STEP 2

Offer the IP Mount up to the frame and install the two countersunk M6 screws and the longer socket head M6 screw with the chain guide in place.

Using a 5mm allen key, torque down the two countersunk screws to 14Nm. The chain guide screw will be torqued down once the Idler is installed.

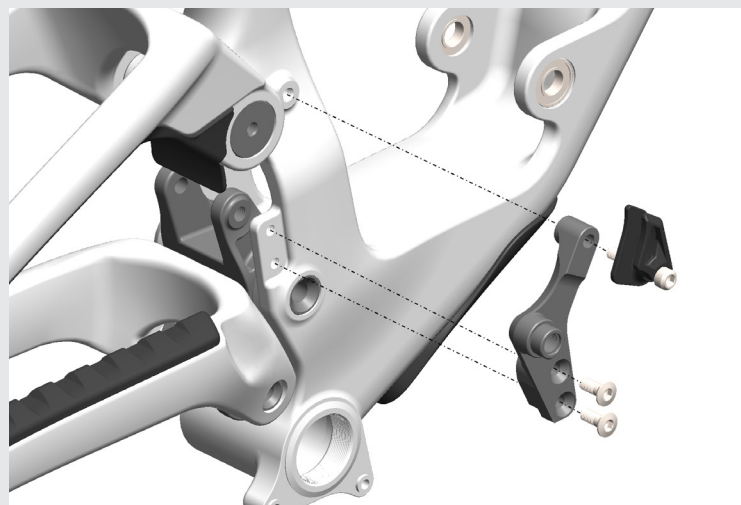

52/55mm MODULAR MOUNTING SYSTEM // DRUID V2



STEP 3

Slide the Idler Pulley onto the mount in the appropriate orientation - Circlip facing in or out, depending on your drivetrain setup. See table on pg. 1 for details. Install the IP Screw and using a 5mm allen key, torque down to 10Nm.

There is no requirement to grease behind the IP Screw since the idler is equipped with a solid-lube bearing. It is a greaseless system.

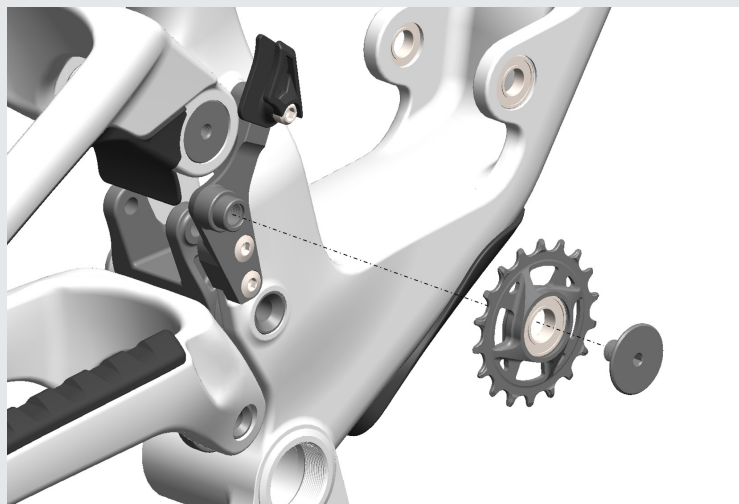

STEP 4

Flip the chain guide down and with a 5mm allen key torque the screw down to 2-3Nm.



52/55mm MODULAR MOUNTING SYSTEM // DRUID V2

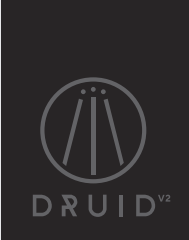

IDLER PULLEY MOUNT

IDLER PULLEY ORIENTATION

	Circlip Facing Out	Circlip Facing In
ANGLED 55mm CL Only	55mm Optimized	N/A
52/55mm CL	52mm	*55mm

* If you are using the **highlighted configuration** seen in the table. Then you are required to use the 3mm plastic spacer (shown in the images below) behind the chain guide to ensure the guide lines up with the Idler.

